

姿図



品番	GSP001DBN-2 (36度配光)
光源	LED
定格光束	765lm
1/2 照度角	35.05°
ビーム角	35.5°

器具効率 100%	上方光束 0%	下方光束 100%	保守率 0.7
-----------	---------	-----------	---------

反射率	天井	80%			70%			50%			30%			10%			0
	壁	50%	30%	10%	50%	30%	10%	50%	30%	10%	50%	30%	10%	50%	30%	10%	0
	床	20%			20%			20%			20%			20%			0
室指数	照 明 率																
0.0	1.19	1.19	1.19	1.16	1.16	1.16	1.11	1.11	1.11	1.06	1.06	1.06	1.02	1.02	1.02	1.00	
1.0	1.12	1.10	1.08	1.10	1.08	1.07	1.06	1.05	1.03	1.02	1.01	1.00	.99	.98	.97	.96	
2.0	1.06	1.03	1.00	1.05	1.02	.99	1.02	.99	.97	.99	.97	.95	.96	.94	.93	.92	
3.0	1.01	.97	.94	.90	.96	.93	.97	.94	.92	.95	.92	.90	.93	.91	.89	.88	
4.0	.96	.92	.89	.95	.91	.88	.93	.90	.87	.91	.89	.86	.90	.87	.85	.84	
5.0	.92	.88	.84	.91	.87	.84	.90	.86	.83	.88	.85	.82	.87	.84	.82	.80	
6.0	.88	.84	.80	.88	.83	.80	.86	.82	.79	.85	.82	.79	.84	.81	.78	.77	
7.0	.85	.80	.77	.84	.80	.77	.83	.79	.76	.82	.78	.76	.81	.78	.75	.74	
8.0	.81	.77	.74	.81	.77	.73	.80	.76	.73	.79	.76	.73	.78	.75	.73	.72	
9.0	.78	.74	.71	.78	.74	.71	.77	.73	.70	.76	.73	.70	.76	.72	.70	.69	
10.0	.76	.71	.68	.75	.71	.68	.75	.71	.68	.74	.70	.68	.73	.70	.68	.67	

配光曲線

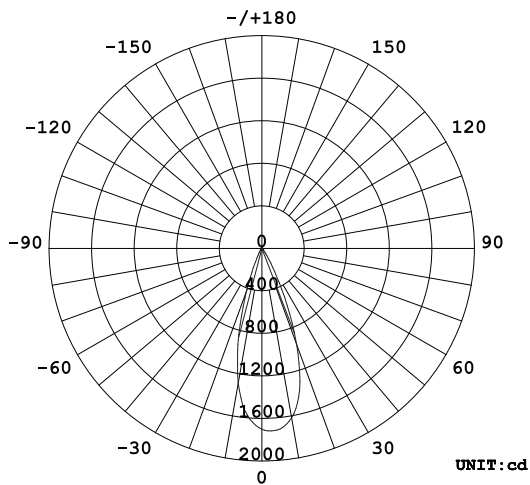

水平面照度

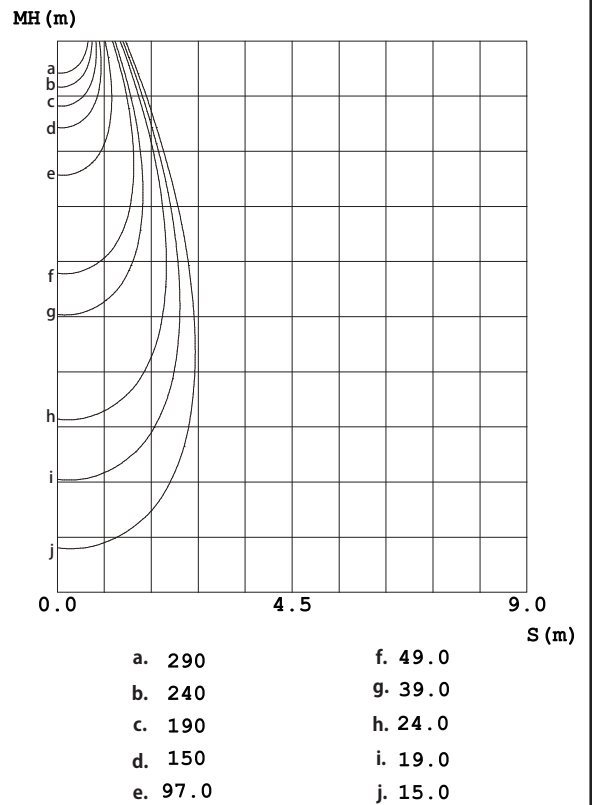

姿図



品番	GSP001DBN-2(24度配光)
光源	LED
定格光束	765lm
1/2 照度角	24.56°
ビーム角	24.7°

器具効率 100%	上方光束 0%	下方光束 100%	保守率 0.7
-----------	---------	-----------	---------

反射率	天井	80%			70%			50%			30%			10%			0
	壁	50%	30%	10%	50%	30%	10%	50%	30%	10%	50%	30%	10%	50%	30%	10%	0
床		20%			20%			20%			20%			20%			0
室指数		照 明 率															
0.0		0.96	0.96	0.96	0.94	0.94	0.94	0.90	0.90	0.90	0.86	0.86	0.86	0.82	0.82	0.82	0.81
1.0		0.91	0.90	0.88	0.90	0.88	0.87	0.86	0.85	0.84	0.83	0.83	0.82	0.81	0.80	0.79	0.78
2.0		0.87	0.85	0.83	0.86	0.84	0.82	0.83	0.81	0.80	0.81	0.80	0.78	0.79	0.78	0.77	0.76
3.0		0.83	0.80	0.78	0.82	0.80	0.78	0.80	0.78	0.76	0.79	0.77	0.75	0.77	0.75	0.74	0.73
4.0		0.80	0.77	0.75	0.79	0.76	0.74	0.78	0.75	0.73	0.76	0.74	0.73	0.75	0.73	0.72	0.71
5.0		0.77	0.74	0.72	0.77	0.73	0.71	0.75	0.73	0.71	0.74	0.72	0.70	0.73	0.71	0.69	0.69
6.0		0.75	0.71	0.69	0.74	0.71	0.69	0.73	0.70	0.68	0.72	0.70	0.68	0.71	0.69	0.67	0.67
7.0		0.72	0.69	0.67	0.72	0.69	0.66	0.71	0.68	0.66	0.70	0.68	0.66	0.69	0.67	0.65	0.65
8.0		0.70	0.67	0.64	0.70	0.66	0.64	0.69	0.66	0.64	0.68	0.66	0.64	0.68	0.65	0.64	0.63
9.0		0.68	0.65	0.63	0.68	0.65	0.62	0.67	0.64	0.62	0.66	0.64	0.62	0.66	0.64	0.62	0.61
10.0		0.66	0.63	0.61	0.66	0.63	0.61	0.65	0.62	0.61	0.65	0.62	0.60	0.64	0.62	0.60	0.60

配光曲線

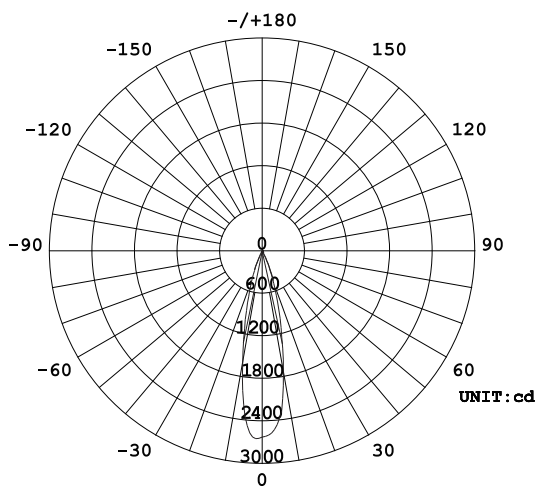

水平面照度

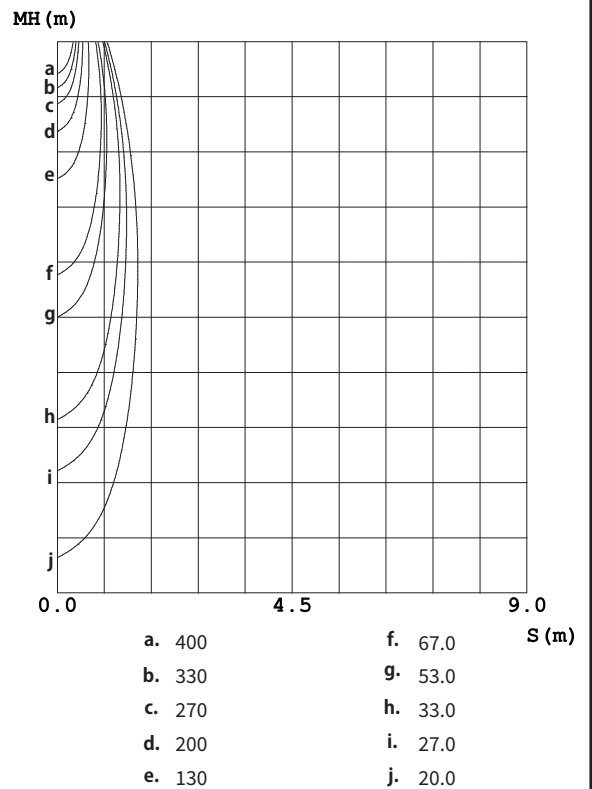

姿図



品番	GSP001DBN-2 (50度配光)
光源	LED
定格光束	765lm
1/2 照度角	47.83°
ビーム角	47.4°

器具効率 100%	上方光束 0%	下方光束 100%	保守率 0.7
-----------	---------	-----------	---------

反射率	天井	80%			70%			50%			30%			10%			0
	壁	50%	30%	10%	50%	30%	10%	50%	30%	10%	50%	30%	10%	50%	30%	10%	0
床	20%	20%			20%			20%			20%			20%			0
室指数	照 明 率																
0.0	1.19	1.19	1.19	1.16	1.16	1.16	1.11	1.11	1.11	1.06	1.06	1.06	1.02	1.02	1.02	1.00	
1.0	1.12	1.09	1.07	1.10	1.08	1.06	1.06	1.04	1.02	1.02	1.01	.99	.98	.97	.97	.95	
2.0	1.05	1.01	.98	1.03	1.00	.97	1.00	.98	.95	.97	.95	.93	.95	.93	.91	.90	
3.0	.99	.95	.91	.98	.94	.90	.95	.92	.89	.93	.90	.88	.91	.88	.86	.85	
4.0	.94	.89	.85	.93	.88	.85	.91	.87	.84	.89	.85	.83	.87	.84	.82	.80	
5.0	.89	.84	.80	.88	.83	.80	.86	.82	.79	.85	.81	.78	.83	.80	.78	.76	
6.0	.84	.79	.75	.84	.79	.75	.82	.78	.75	.81	.77	.74	.80	.76	.74	.72	
7.0	.80	.75	.71	.80	.75	.71	.78	.74	.71	.77	.73	.70	.76	.73	.70	.69	
8.0	.76	.71	.68	.76	.71	.67	.75	.70	.67	.74	.70	.67	.73	.69	.67	.65	
9.0	.73	.68	.64	.73	.68	.64	.72	.67	.64	.71	.67	.64	.70	.66	.64	.62	
10.0	.70	.65	.61	.69	.64	.61	.69	.64	.61	.68	.64	.61	.67	.63	.61	.60	

配光曲線

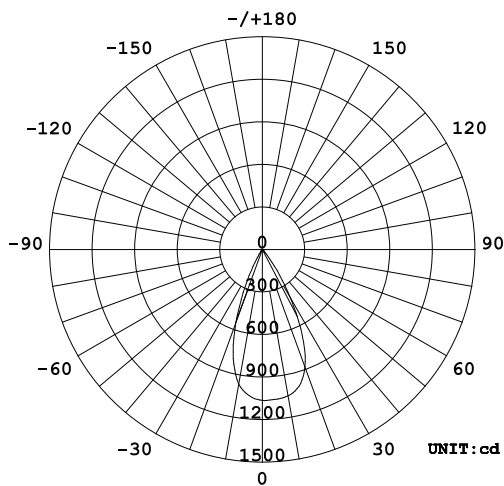

水平面照度

